

Ceiling Mount Cooling Systems

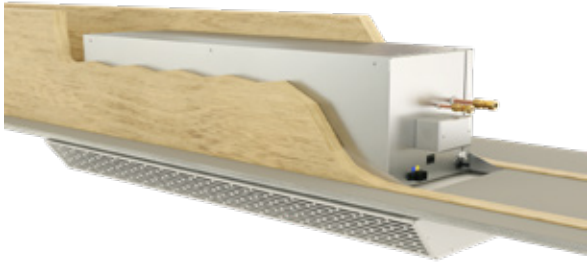

Wine is your Passion. Preserving it is ours.

Wine Guardian ceiling mount cooling systems are quiet, split wine conditioning systems that are ideal for small- to mid-size wine rooms with no space to install a traditional unit. These units were designed specifically for ceiling mounting and fit comfortably between standard joist construction — making them ideal for applications such as a wine storage display with living space around it or an all-glass wine room. Ceiling mount systems are available in two configurations with capacities to 4,300 BTU/H.

Standard Features

- Designed specifically for recessed ceiling mounting
- Quiet operation
- Light-weight, corrosion-proof construction
- Paintable grille to match wine cellar design
- Advanced condensate removal system
- Easy to install & maintain
- Paired with a specifically-designed Wine Guardian condensing unit
- Low ambient protection
- Wine Guardian Wireless2Base controls

Options

- Electric Heater
- Freestanding humidifier
- Xtreme low ambient protection
- Remote Sensors
- Moniteur Du Vin



Rendering of the ceiling mount unit installed between wooden floor joists.
(Joist height has been minimized to show unit)

Note: Ceiling Mount Unit is Patent Pending.

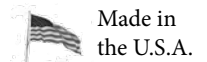

Wine Guardian USA:
1 (800) 825 3268 | 1 (315) 452 7400
wineguardian.com | info@wineguardian.com

Wine Guardian European Office:
Pestalozzistrasse 2, CH-8201 Schaffhausen, Switzerland
+41 (0) 52 224-0490

Find a Distributor

Ceiling Mount Cooling Systems



Specifications

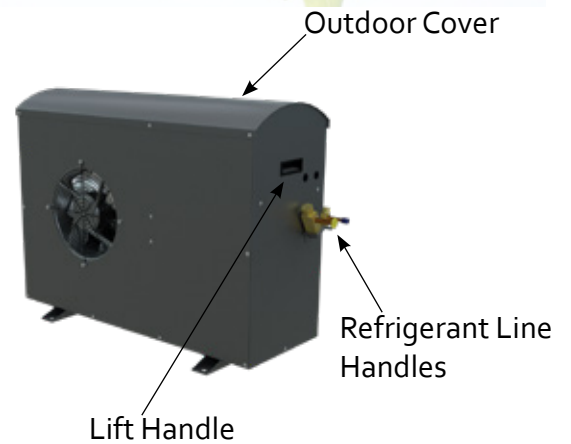
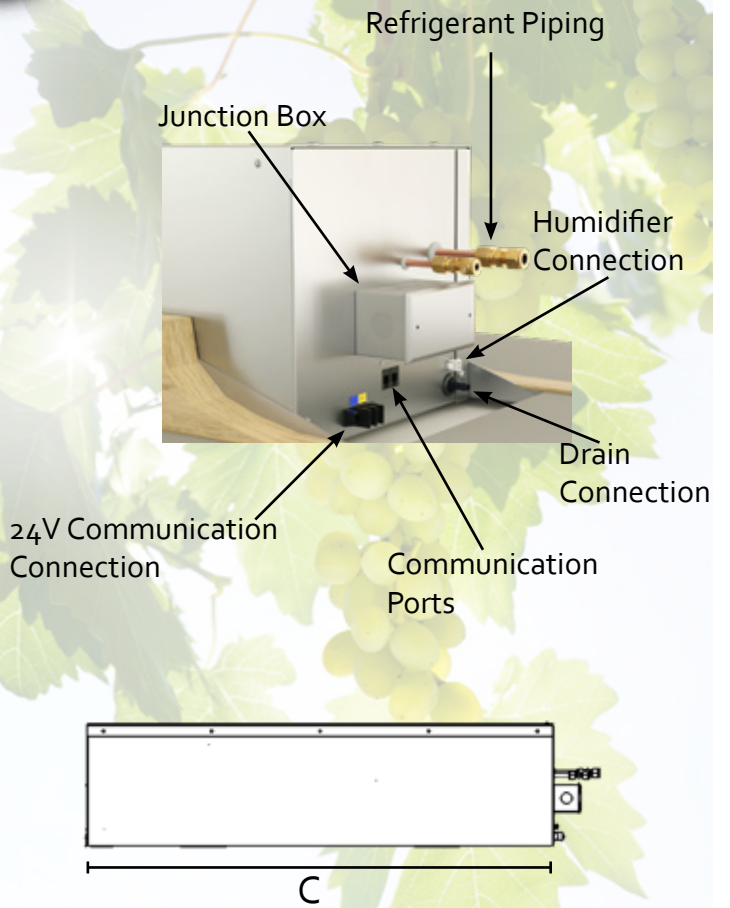
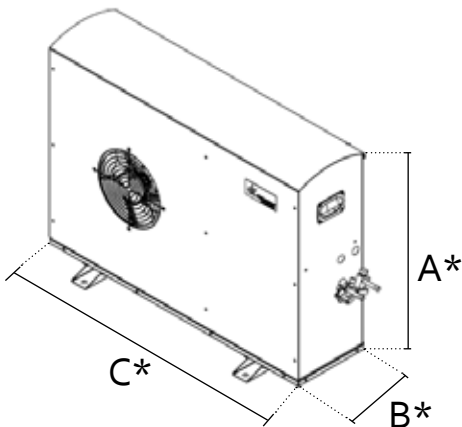
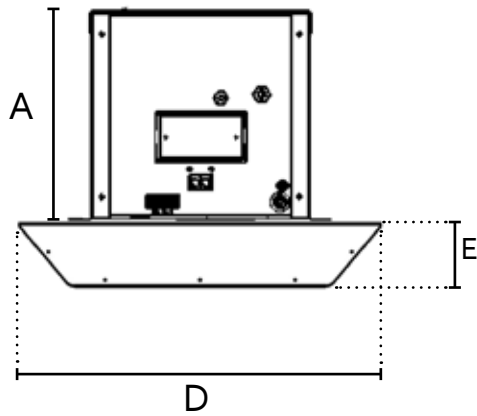

*These measurements relate to the condensing unit in the table on the next page.
 Condensing unit is patented. US Patent No. D791295. EU Patent No. 003189349-0001.

Wine Guardian USA:
 1 (800) 825 3268 | 1 (315) 452 7400
wineguardian.com | info@wineguardian.com

Wine Guardian European Office:
 Pestalozzistrasse 2, CH-8201 Schaffhausen, Switzerland
 +41 (0) 52 224-0490

Find a Distributor

Ceiling Mount Cooling Systems



60Hz System Specifications

Model	Capacity (BTU/H)	A	B	C	D	E	Electrical	Sound (DBA)	Weight (lbs.)
CS025	2,900	9.55"	10.18"	36.52"	18.07"	3.16"	115V / 1ph / 60Hz	53	51
Condensing Unit	—	26.00"	12.00"	34.00"	—	—	208 - 230V / 1ph / 60Hz	52	57
CS050	4,300	9.55"	10.18"	36.52"	18.07"	3.16"	115V / 1ph / 60Hz	57	51
Condensing Unit	—	26.00"	12.00"	34.00"	—	—	208 - 230V / 1ph / 60Hz	55	75



Made in the U.S.A.

50Hz System Specifications

Model	Capacity (Watts)	Measurements in mm					Electrical	Sound (DBA)	Weight (kg.)
		A	B	C	D	E			
WGC40	TBD	243	260	930	459	80	220 - 240V / single-phase / 50Hz	53	23
Condensing Unit	—	660	305	864	—	—	220 - 240V / single-phase / 50Hz	52	26
WGC75	TBD	243	260	930	459	80	220 - 240V / single-phase / 50Hz	57	23
Condensing Unit	—	660	305	864	—	—	220 - 240V / single-phase / 50Hz	55	34



Made in the U.S.A.

Sizing note: Many variables affect proper unit sizing, including type of construction, insulation values, amount of glass, residential vs. commercial applications, etc. Proper unit size should only be determined by performing a heat load calculation. While the Wine Guardian cooling calculator is a good guideline, be sure to perform an in-depth heat load calculation and do not size purely on cubic feet. Check with your Wine Guardian authorized distributor for more information. Sound data is from 6-feet away. Not all systems may offer all the features described above. For instance, humidity can only be controlled if the unit is equipped with a humidifier. Wine Guardian systems are made in the USA. Manufacturer reserves the right to make changes to this document, without prior notice, at its sole discretion.

Rev 10/19

Wine Guardian USA:
1 (800) 825 3268 | 1 (315) 452 7400
wineguardian.com | info@wineguardian.com

Wine Guardian European Office:
Pestalozzistrasse 2, CH-8201 Schaffhausen, Switzerland
+41 (0) 52 224-0490

Find a Distributor